

1. Communications Courses

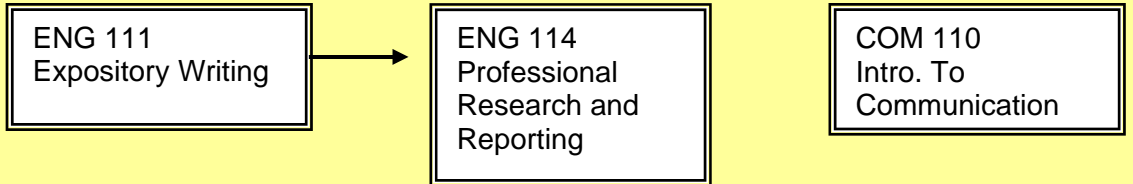

2. Mathematics Courses

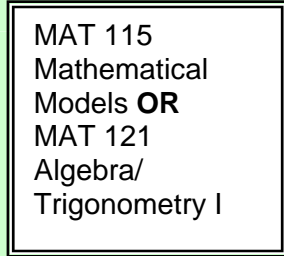

3. Physical & Natural Sciences

4. Social Sciences & Humanities

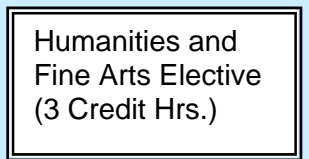
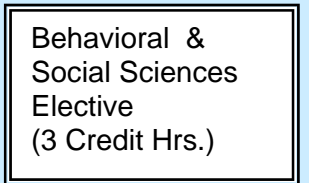

5. Technical Content

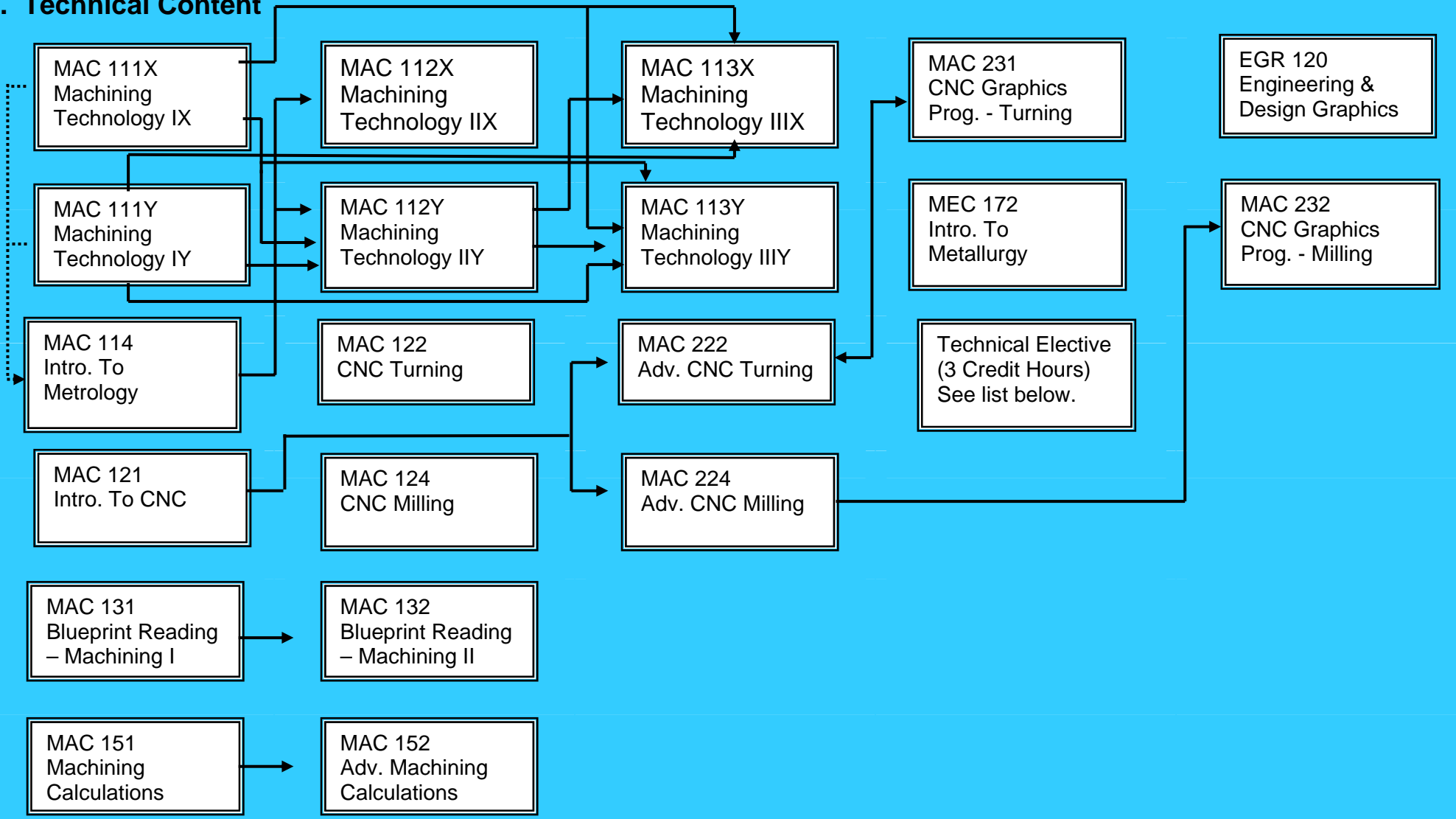

Legend:
 → Prerequisite or Corequisite
 Choice of Prerequisite

Note:
 Both MAC 151 Machining Calculations and MAC 152 Advanced Machining Calculations contribute to both technical and mathematical content categories.

MACHINING TECHNOLOGY CURRICULUM (A50300)

MAC 111X and MAC 111Y = MAC 111
 MAC 112X and MAC 112Y = MAC 112
 MAC 113X and MAC 113Y = MAC 113

Technical Electives
 COE 112 Cooperative Work Experience I
 COE 122 Cooperative Work Experience II
 DFT 121 Intro. To G. D. & T.
 DFT 154 Intro. To Solid Modeling
 ISC 132 Manufacturing Quality Control
 WLD 112 Basic Welding Processes